



B3887BHF

Wastewater

Goulds Pumps

WS_BHF Series Model 3887BHF

Submersible Sewage Pump

Prosurance available for residential applications.



FEATURES

- **Impeller:** Cast iron, enclosed, non-clog, dynamically balanced with pump out vanes for mechanical seal protection.
- **Casing:** Cast iron flanged volute type for maximum efficiency. Designed for easy installation on A10-20 slide rail or base elbow rail systems.
- **Mechanical Seal:** Silicon Carbide vs. Silicon Carbide sealing faces for superior abrasive resistance, stainless steel metal parts, BUNA-N elastomers.
- **Shaft:** Corrosion resistant, 300 series stainless steel. Threaded design. Locknut on all models to guard against component damage on accidental reverse rotation.
- **Fasteners:** 300 series stainless steel.
- Capable of running dry without damage to components.
- Designed for continuous operation, when fully submerged.



AGENCY LISTINGS



Tested to UL 778 and CSA 22.2 108 Standards
By Canadian Standards Association — File #LR38549
Goulds Pumps is ISO 9001 Registered.

Goulds Pumps is a brand of ITT Corporation.

www.goulds.com

Engineered for life

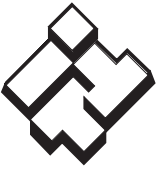

GOULDS PUMPS Wastewater

APPLICATIONS

Specifically designed for the following uses:

- Homes
- Sewage systems
- Dewatering/Effluent
- Water transfer
- Light industrial
- Commercial applications

Anywhere waste or drainage must be disposed of quickly, quietly and efficiently.

SPECIFICATIONS

Pump

- Solids handling capabilities: 2" maximum.
- Capacities: up to 220 GPM.
- Total heads: up to 81 feet TDH.
- Discharge size: 2" NPT threaded companion flange as standard. 3" option available but must be ordered separately. (Order no. A1-3)
- Temperature: 104°F (40°C) continuous
140°F (60°C) intermittent.

MOTORS

- Fully submerged in high grade turbine oil for lubrication and efficient heat transfer. All ratings are within the working limits of the motor.
- Class B insulation on 1/3-1 1/2 HP models.
- Class F insulation on 2 HP models.

Single phase (60 Hz):

- Capacitor start motors for maximum starting torque.
- Built-in overload with automatic reset.
- SJTOW or STOW severe duty oil and water resistant power cords.
- 1/3 – 1 HP models have NEMA three prong grounding plugs.
- 1 1/2 HP and larger units have bare lead cord ends.

Three phase (60 Hz):

- Class 10 overload protection must be provided in separately ordered starter unit.
- STOW power cords all have bare lead cord ends.
- **Designed for Continuous Operation:** Pump ratings are within the motor manufacturer's recommended working limits, can be operated continuously without damage when fully submerged.
- **Bearings:** Upper and lower heavy duty ball bearing construction.
- **Power Cable:** Severe duty rated, oil and water resistant. Epoxy seal on motor end provides secondary moisture barrier in case of outer jacket damage and to prevent oil wicking. Standard cord is 20'. Optional lengths are available.
- **Motor Cover O-ring:** Assures positive sealing against contaminant and oil leakage.

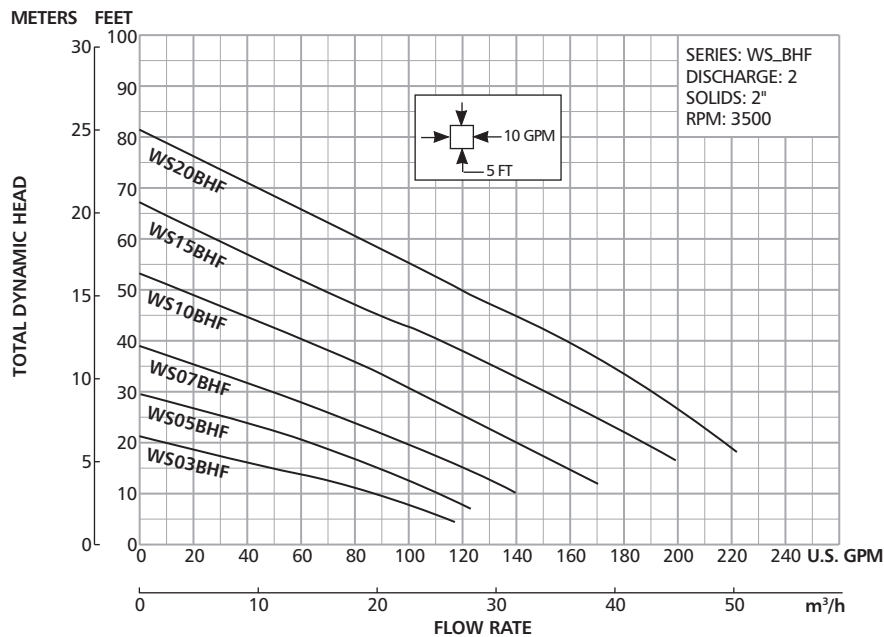

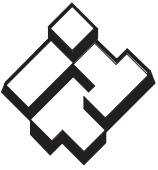

GOULDS PUMPS

Wastewater

MOTOR AND MODEL INFORMATION

ORDER NUMBER	HP	PHASE	VOLTS	RPM	IMPELLER DIA. (IN.)	MAX. AMPS	LOCKED ROTOR AMPS	KVA CODE	FULL LOAD MOTOR EFF. %	RESISTANCE		
										START	LINE-LINE	
WS0311BHF	0.33	1	115	3500	2.94	12.4	46.0	M	54	7.5	1.0	
WS0318BHF	0.33	1	208			6.8	31.0	K	68	9.7	2.4	
WS0312BHF	0.33	1	230			6.2	34.5	M	53	9.6	4.0	
WS0511BHF	0.5	1	115		3.19	14.5	46.0	M	54	7.5	1.0	
WS0518BHF	0.5	1	208			8.4	31.0	K	68	9.7	2.4	
WS0512BHF	0.5	1	230			7.6	34.5	M	53	9.6	4.0	
WS0538BHF	0.5	3	200			4.9	22.6	R	68	—	3.8	
WS0532BHF	0.5	3	230			3.6	18.8	R	70	—	5.8	
WS0534BHF	0.5	3	460			1.8	9.4	R	70	—	23.2	
WS0537BHF	0.5	3	575			1.5	7.5	R	62	—	35.3	
WS0718BHF	0.75	1	208			3.44	11.0	31.0	K	68	9.7	2.4
WS0712BHF	0.75	1	230				10.0	27.5	J	65	12.2	2.7
WS0738BHF	0.75	3	200		6.2		20.6	L	64	—	5.7	
WS0732BHF	0.75	3	230		5.4		15.7	K	68	—	8.6	
WS0734BHF	0.75	3	460		2.7		7.9	K	68	—	34.2	
WS0737BHF	0.75	3	575		2.2		9.9	L	78	—	26.5	
WS1018BHF	1	1	208		3.75	14.5	59.0	K	68	9.3	1.1	
WS1012BHF	1	1	230			13.0	36.2	J	69	10.3	2.1	
WS1038BHF	1	3	200			8.6	27.6	M	77	—	2.7	
WS1032BHF	1	3	230			7.5	24.1	L	79	—	4.1	
WS1034BHF	1	3	460			3.8	12.1	L	79	—	16.2	
WS1037BHF	1	3	575			3.1	9.9	L	78	—	26.5	
WS1512BHF	1.5	1	230		4.00	18.0	52.0	J	67	2.76	0.53	
WS1538BHF	1.5	3	200			10.0	42.4	K	78	—	1.7	
WS1532BHF	1.5	3	230			9.6	42.4	K	78	—	1.7	
WS1534BHF	1.5	3	460			4.8	21.2	K	78	—	6.6	
WS1537BHF	1.5	3	575			3.9	16.3	L	78	—	10.5	
WS2012BHF	2	1	230		4.44	18.0	49.6	F	78	3.2	1.1	
WS2038BHF	2	3	200			12.0	42.4	K	78	—	1.7	
WS2032BHF	2	3	230			11.6	42.4	K	78	—	1.7	
WS2034BHF	2	3	460	5.8		21.2	K	78	—	6.6		
WS2037BHF	2	3	575	4.7		16.3	L	78	—	10.5		

DIMENSIONS

(All dimensions are in inches. Do not use for construction purposes.)

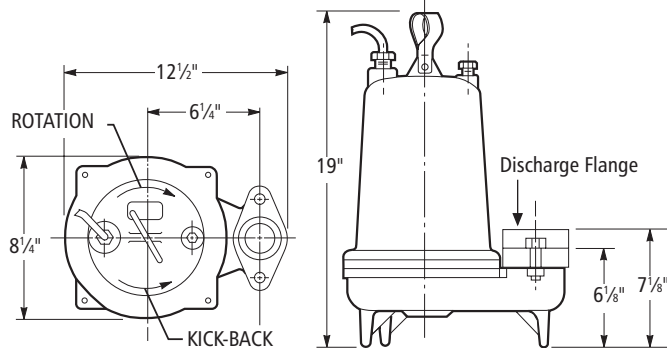

Discharge Flange:

- ① 2" NPT standard
- ② 3" NPT optional (order an A1-3)



Wastewater

PERFORMANCE RATINGS (gallons per minute)

Order No.	WS03BHF	WS05BHF	WS07BHF	WS10BHF	WS15BHF	WS20BHF
HP ▶	1/3	1/2	3/4	1	1 1/2	2
RPM ▶	3500	3500	3500	3500	3500	3500
Total Head Feet of Water	10 ▶	86	110	140	–	–
	15	48	88	120	158	–
	20	–	62	98	139	186
	25	–	32	74	120	170
	30	–	–	49	101	150
	35	–	–	21	82	130
	40	–	–	–	60	110
	45	–	–	–	38	88
	50	–	–	–	–	67
	55	–	–	–	–	47
	60	–	–	–	–	29
	65	–	–	–	–	–
	70	–	–	–	–	–
	75	–	–	–	–	–

COMPONENTS (for reference only)

Item No.	Description
1	Impeller
2	Casing
3	Mechanical Seal
4	Motor Shaft
5	Motor
6	Ball Bearings
7	Power Cable
8	Casing O-Ring

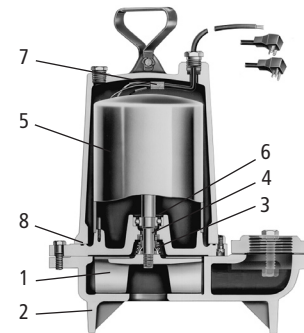

* For repair parts, reference repair parts book.



Goulds Pumps and the ITT Engineered Blocks Symbol are registered trademarks and tradenames of ITT Corporation.

SPECIFICATIONS ARE SUBJECT TO CHANGE WITHOUT NOTICE.

B3887BHF October, 2008

Copyright (c) 2008 ITT Corporation

Engineered for life